

## MEASURES

DIMENSIONS H x W x D	943x1091x465 mm
GROSS/NET WEIGHT	191+55/171+50 kg
FIREWOOD ENTRANCE	870x300 mm
SMOKE FLUE	Ø 150-153 mm Top
EXTERNAL AIR INTAKE	Ø 80 mm

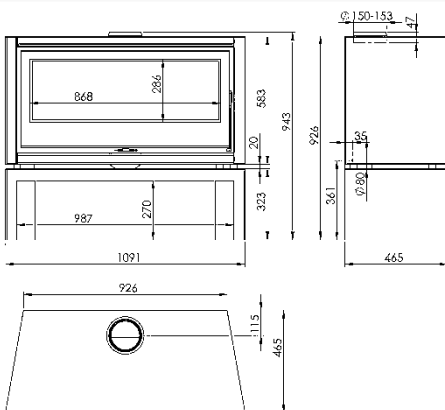







## CHARACTERISTICS

CAST IRON GRILL	
PANORAMIC VISION	
DOUBLE STEEL BODY SHEET	5+3 mm
NOMINAL HEAT OUTPUT	8,9 KW
EFFICIENCY	80,8 %
CO EMISSIONS	0,10 %
HEAT RESISTANT PAINT	800°C
CERAMIC GLASS HEAT RESISTANCE	750°C



## PRODUCT PLUS

### ECODESIGN

-  EXTERNAL AIR INTAKE
-  VERMICULITE LINING
-  PRINTED GLASS
-  WOOD LOGS 80 CM
-  240 m<sup>3</sup> HEATING VOLUME
-  CLEAN GLASS SYSTEM
-  DOUBLE COMBUSTION
-  DOUBLE STEEL BODY SHEET 5 + 3 MM



EAN STOVE BENCH 8426964243550  
REF. STOVE BENCH 24355

EAN PANORAMIC STOVE 8426964243505  
REF. PANORAMIC STOVE 24350

# PANORAMIC + STOVE BENCH

## EcoDesign



**BlmSchV2**

