

MEASURES	
DIMENSIONS H x W x D	627x1120x505mm
GROSS/NET WEIGHT	180/152 kg
FIREWOOD ENTRANCE	885x300 mm
SMOKE FLUE	Ø 150-153 mm Top
EXTERNAL AIR INTAKE	Ø 80 mm

CHARACTERISTICS	
CAST IRON GRILL	
PANORAMIC VISION	
STEEL BODY SHEET	3 mm
NOMINAL HEAT OUTPUT	8,9 KW
EFFICIENCY	80,8 %
CO EMISSIONS	0,10 %
HEAT RESISTANT PAINT	800°C
CERAMIC GLASS HEAT RESISTANCE	750°C

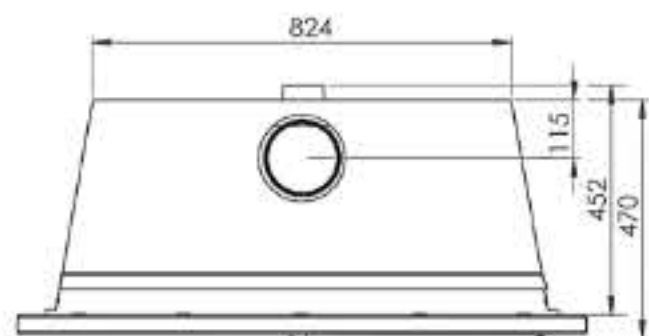
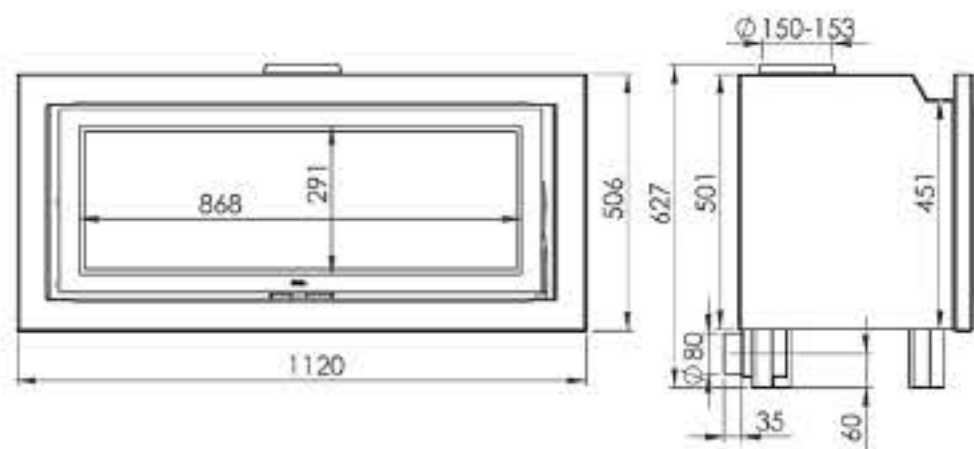

## PRODUCT PLUS

### ECODESIGN

-  EXTERNAL AIR INTAKE
-  RÉFRACTAIRE
-  PRINTED GLASS
-  WOOD LOGS 80 CM
-  HEATING VOLUME
-  CLEAN GLASS SYSTEM
-  TRIPLE COMBUSTION



EAN 8426964249057  
REF. 24905



BlmSchV2



# F-1120 EcoDesign

